

PLEASE CHECK WWW.MOLEX.COM FOR LATEST PART INFORMATION

Part Number: [0002062101](#)
Status: **Active**
Overview: [standard_062](#)
Description: 1.57mm (.062") Diameter, Standard .062" Pin and Socket Crimp Terminal, Series 1560, Male, with Tin (Sn) Plated Brass Contact, 18-24 AWG, Reel

Documents:

[Drawing \(PDF\)](#) [RoHS Certificate of Compliance \(PDF\)](#)

General

Product Family	Crimp Terminals
Series	1560
Crimp Quality Equipment	Yes
Overview	standard_062
Product Name	Standard .062"

Physical

Gender	Male
Material - Metal	Brass
Material - Plating Mating	Tin
Material - Plating Termination	Tin
Packaging Type	Reel
Plating min: Mating (µin)	20
Plating min: Mating (µm)	0.50
Plating min: Termination (µin)	20
Plating min: Termination (µm)	0.50
Termination Interface: Style	Crimp or Compression
Wire Insulation Diameter	1.52-3.05mm (.060-.120")
Wire Size AWG	18, 20, 22, 24
Wire Size mm ²	N/A

Material Info

Old Part Number	1560-(P901)
-----------------	-------------

Reference - Drawing Numbers

Sales Drawing	SD-1560-*
---------------	-----------



image - Reference only

EU RoHS

**ELV and RoHS
Compliant**

REACH SVHC

Contains SVHC: No

Halogen-Free

Status

Not Reviewed

China RoHS



**Need more information on product
environmental compliance?**

Email productcompliance@molex.com
 For a multiple part number RoHS Certificate of Compliance, [click here](#)

Please visit the [Contact Us](#) section for any non-product compliance questions.

Search Parts in this Series

[1560Series](#)

Application Tooling | [FAQ](#)

Tooling specifications and manuals are found by selecting the products below. Crimp Height Specifications are then contained in the Application Tooling Specification document.

Global

Description	Product #
Mini-Mac™ Applicator	0638914000
Hand Crimp Tool for Standard .062" Pin and Socket Crimp Terminals, 18-24 AWG	0638191300
Manual Extraction Tool	0011030002
Terminator Die	0011402004
Hand Crimper - DISTRIBUTION ONLY	0638111000

Japan

Description

Product #

Hand Insertion Tool 0011020001

This document was generated on 05/17/2010

PLEASE CHECK WWW.MOLEX.COM FOR LATEST PART INFORMATION

PART NO.	ENG. NO.
02-06-2101	1560-(P901)
02-06-2103	1560-(P901)L
02-06-6101	1560-(561)
02-06-6102	1560-(561)L
02-06-6118	1560-(228)
02-06-6119	1560-(228)L
02-06-6116	1560-(231)
02-06-6112	1560-(231)L
02-06-6100	1560-(550)
02-06-6103	1560-(550)L
02-06-6105	1560-(591)
02-06-6104	1560-(591)L

LEGEND

1560-(****)*

P=PREPLATE
BLANK=POSTPLATE

FORM
BLANK=CHAIN
L=LOOSE

FINISH CODE

- NOTES:
- MATERIAL: BRASS
 - FINISHES:
 - 901 HOT TIN DIP (.00051)/.000020 MIN.
 - *228 SELECT GOLD PLATE (.00075)/.000030 MIN. IN CONTACT AREA, SELECT TIN (.00250)/.000100 MIN. IN CRIMP AREA OVER (.00125)/.000050 MIN. NICKEL OVERALL.
 - *231 SELECT GOLD PLATE (.00125)/.000050 MIN. IN CONTACT AREA, SELECT TIN (.00250)/.000100 MIN. IN CRIMP AREA OVER (.00125)/.000050 MIN. NICKEL OVERALL.
 - 561 SELECT GOLD PLATE (.00076)/.000030 MIN. IN CONTACT AREA, OVER (.00127)/.000050 MIN. NICKEL OVERALL.
 - 591 SELECT GOLD PLATE (.00127)/.000050 MIN. IN CONTACT AREA, OVER (.00127)/.000050 MIN. NICKEL OVERALL WITH (.000025)/.000010 MAX. GOLD FLASH OVERALL.
 - 550 SELECT GOLD PLATE (.00038)/.000015 MIN. IN CONTACT AREA, OVER (.00076)/.000030 MIN. NICKEL OVERALL WITH (.000025)/.000010 MAX. GOLD FLASH OVERALL.
 - * THE PRIMARY SHIPPING CARTON WILL BE LABELED, "COMPLIANT TO RoHS DIRECTIVE" 2002/95/EC AND ELV ANNEX II OF DIRECTIVE 2000/53/EC, AND CARTONS WITHOUT THIS LABEL MAY CONTAIN PRODUCT WITH TIN-LEAD.
 - PRODUCT SPECIFICATION: PS-02-06
 - PACKAGING INFORMATION: NOT AVAILABLE
 - TERMINAL FOR USE WITH (157)/.062 DIA. SERIES HOUSINGS AND WILL ACCEPT 18 THRU 24 AWG WIRE.

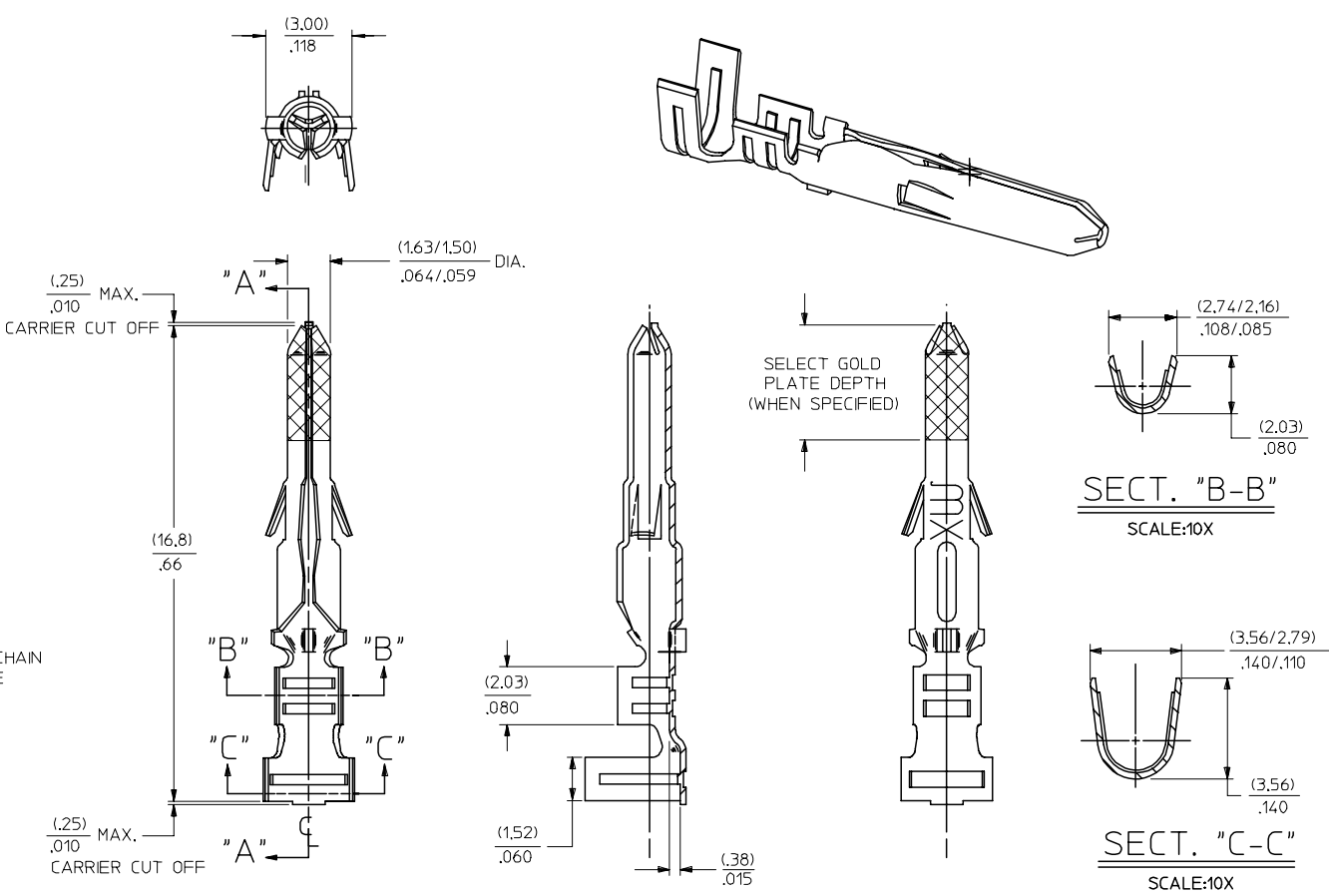

AP	REVSE Sn/Pb PLATE REDRAWN TO ME10 UCP2004-2097 RHOLTS 5/07/04
AO	REINSTATE 02066105 UCP2003-1827 ELHAG, 03/02/24
AN	OBSOLETE P/N UCR2002-0270 COMERC 01/9/25
AM1	ADDED ISO VIEW UCR1998-0228 WANG 98-05-21
AM	REV. & REDRAWN PER ECR 10372 GEP 8-19-87 RW

REFER TO REVISION BLOCK EC NO: 2002/2004/2097 DRWNR:RHOLTS 2004/05/14 CHKD: 2004/05/14 APPR:FSMITH 2004/05/18	QUALITY SYMBOLS ▽ = 0 ▽ = 0	GENERAL TOLERANCES (UNLESS SPECIFIED) <table border="1"> <thead> <tr> <th></th> <th>mm</th> <th>INCH</th> </tr> </thead> <tbody> <tr> <td>4 PLACES</td> <td>± .---</td> <td>± .---</td> </tr> <tr> <td>3 PLACES</td> <td>± .---</td> <td>± .010</td> </tr> <tr> <td>2 PLACES</td> <td>± 0.25</td> <td>± .014</td> </tr> <tr> <td>1 PLACE</td> <td>± 0.35</td> <td>± .---</td> </tr> </tbody> </table>		mm	INCH	4 PLACES	± .---	± .---	3 PLACES	± .---	± .010	2 PLACES	± 0.25	± .014	1 PLACE	± 0.35	± .---	SCALE 8:1 DESIGN UNITS INCH DIMENSION STYLE IN/MM	THIRD ANGLE PROJECTION TITLE CRIMP TERMINAL, MALE .062 DIA. FOR 18-24 AWG WIRE	REVISE ON CAD ONLY
		mm	INCH																	
4 PLACES	± .---	± .---																		
3 PLACES	± .---	± .010																		
2 PLACES	± 0.25	± .014																		
1 PLACE	± 0.35	± .---																		
DRAFT WHERE APPLICABLE MUST REMAIN WITHIN DIMENSIONS	DRAWN BY GEP DATE 1987/08/19 CHECKED BY RW DATE 1987/08/19 APPROVED BY RAS DATE 1987/08/19	MATERIAL NO. SEE CHART DOCUMENT NO. SD-1560-* SHEET NO. 1 OF 1	MOLEX INCORPORATED																	